

Model SL47A

Formed Steel Louver • 4" Deep • 45° Straight Blades • Adjustable • Galvanized Steel

STANDARD CONSTRUCTION

- FRAME:** 18-GA. galvanized steel.
- BLADE:** 18-GA. galvanized steel, open to 45°.
- AXLES:** ½" dia. extruded aluminum "pin-lock" rod with "double-sealed" bearings.
- CONSTRUCTION:** Welded and/or riveted for maximum service.
- LINKAGE:** Concealed in one jamb out of airstream, up to 48" width. Concealed in both jambs, 48" up to 60" width.
- SEALS:** Stainless steel at jambs.
- SCREEN:** (When indicated, specify exterior or interior) ½" sq. mesh, 19-GA. galvanized steel, .041".
- FINISH:** Mill.

OPTIONS

- Frames and Blades of other gauges
- Other materials - Stainless steel, Copper, Aluminum, etc.
- Neoprene blade edge seals
- Finishes - Enamels, Epoxies, etc.
- Screens - Insect screen 1⁵/₁₆ aluminum mesh, .011"
 - or- ½" flattened aluminum, .051",
 - or- ¼" sq. mesh, 18-GA galvanized steel, .047",
 - or- ½" sq. mesh, 18-GA stainless steel, .047",
- And others.

NOTES

1. Nominal deductions will be made to the opening size given.
2. Approximate shipping weight is 8.0 lbs./sq.ft.

LOUVER SIZES

Min Panel	Max Single Panel
12"W x 12"H	60"W x 96"H

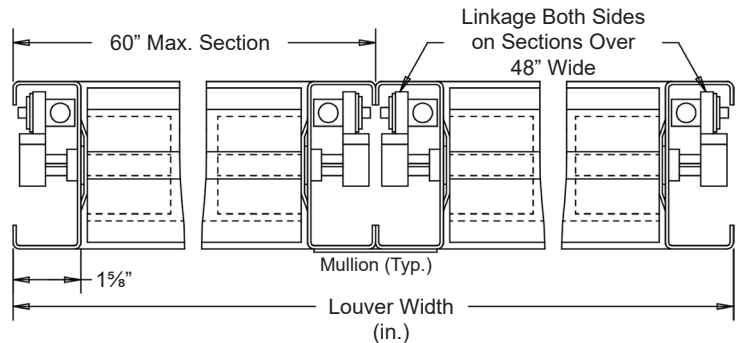
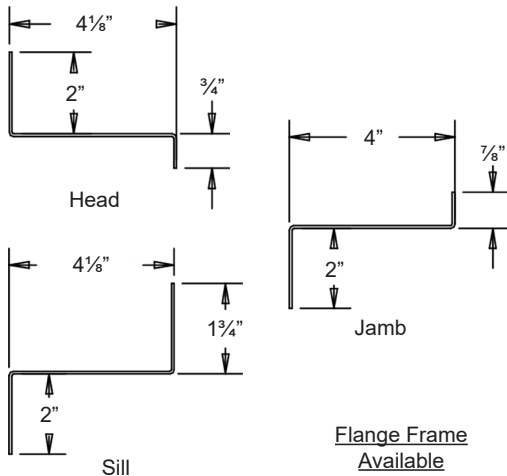
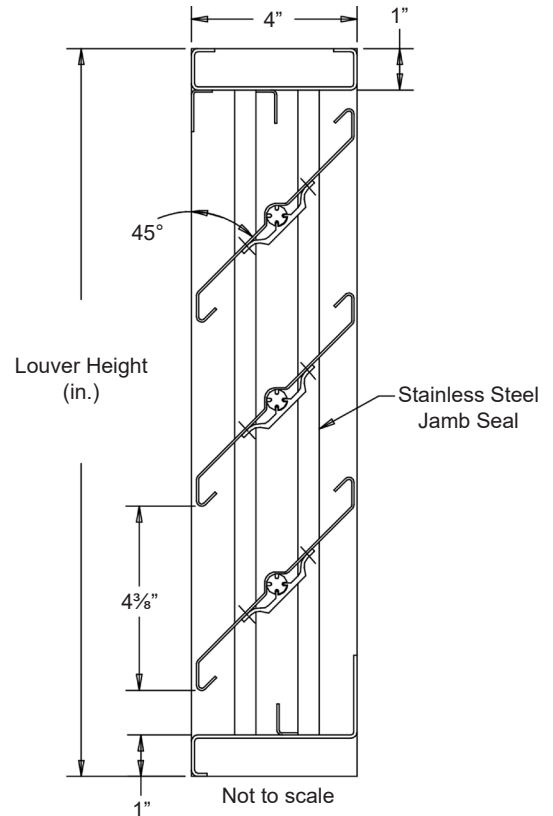

Item #	Qty	Width	Height	Width	Height	Mullion	Type	Location	Union Made
		Opening Size		Louver Size			Screens		
Arch. / Eng. :						EDR:		ECN:	Job:
Contractor:									
Project:						Date:		DWN:	DWG:

In the interest of product development, Louvers & Dampers reserves the right to make changes without notice.

www.louvers-dampers.com

450 Riverside Drive • Wyalusing PA, 18853 • Phone 570-746-1888 • Fax 570-746-9286



Model SL47A

Formed Steel Louver • 4" Deep • 45° Straight Blades • Adjustable • Galvanized Steel

PERFORMANCE DATA

Pressure Drop: .10 in. w.g. at 720 fpm
 Free Area: 7.79 sq.ft. = 48.7% for 48"W x 48"H sample tested in accordance with AMCA Standard 500-L
 Beginning Point of Water Penetration: 645 fpm

Ratings do not include the effects of a bird screen.

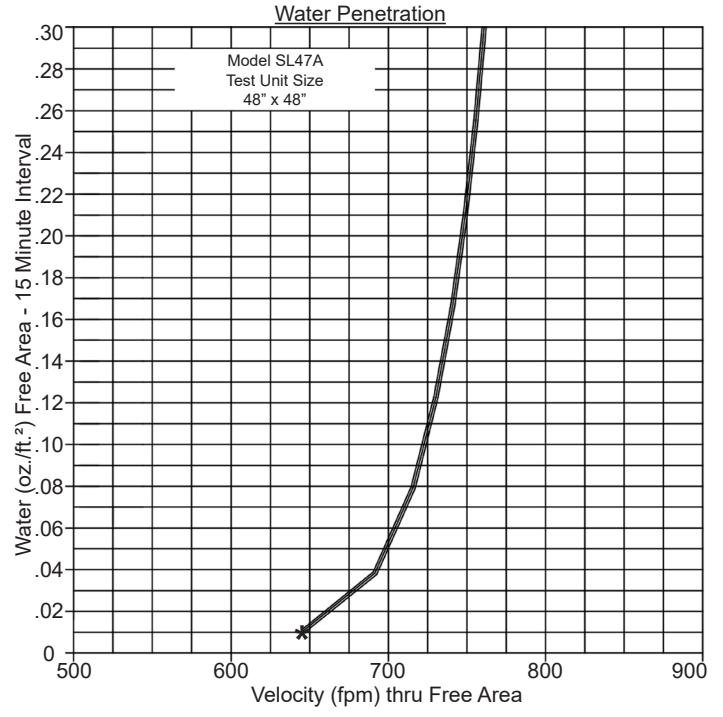
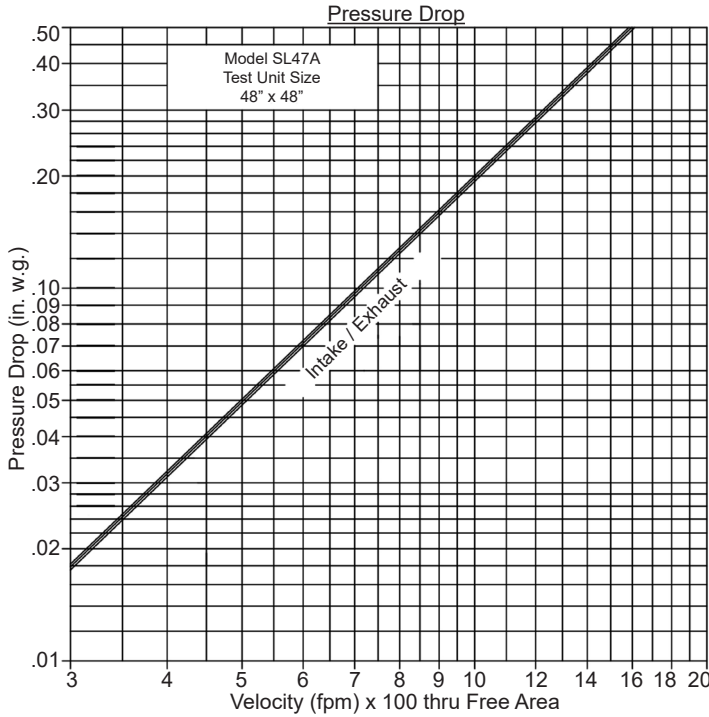

645 (FPM) Beginning Point of Water Penetration.

Intake air converted to standard air density.
 Tested to AMCA Standard 500-L, Figure 5.5.

		Free Area (sq. ft.)								
		Width (in.)								
Height (in.)		12"	18"	24"	30"	36"	42"	48"	54"	60"
		12"	.25	.39	.54	.69	.84	.99	1.13	1.28
24"	.72	1.15	1.59	2.02	2.45	2.89	3.32	3.75	4.18	
36"	1.24	1.98	2.72	3.47	4.21	4.95	5.70	6.44	7.18	
48"	1.69	2.71	3.73	4.74	5.76	6.78	7.79	8.81	9.82	
60"	2.13	3.41	4.69	5.97	7.25	8.53	9.81	11.09	12.37	
72"	2.62	4.19	5.76	7.33	8.90	10.47	12.04	13.61	15.18	
84"	3.13	5.01	6.89	8.77	10.65	12.53	14.41	16.29	18.17	
96"	3.58	5.73	7.88	10.02	12.17	14.32	16.47	18.62	20.76	